

AURORA ACCESSORIES

1040 311

JUNE 2012

1/2" + 2"

AURORA ACCESSORIES

1040 313

JUNE 2012

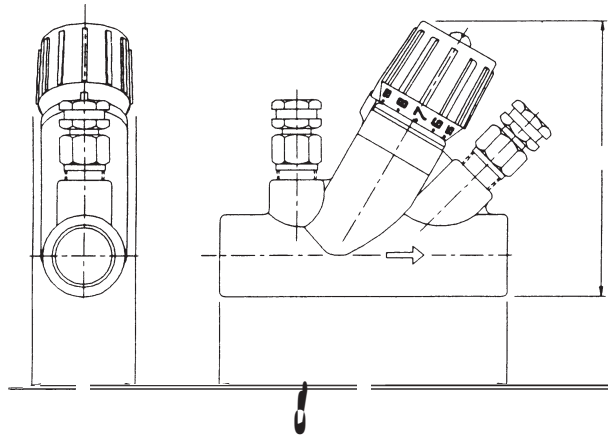

DIMENSIONS ()					
M	P S	A	B	C	W . . (.)
CBV50M	1/2"	3-1/8 (79)	3-17/32 (90)	1-11/32 (34)	1.1 (0.5)
CBV75M	3/4"	3-25/32 (96)	3-5/8 (92)	1-11/32 (34)	1.19 (0.54)

N : All dimensions are in inches (mm) and weights in lbs. (kg).

S	
Connection	Solder Joint
Material of Construction	Brass
Maximum Working Pressure	300 psi (2068 kPa)
Maximum Operating Temperature	250°F (121°C)
Handwheel	1 Turn 360°

N :

1. Solder style models are supplied unassembled. Valve body must be soldered in the line before assembly.
2. Refer to C_v curves for sizing and balancing, giving pressure drop at different settings and flow rates.
3. All valves furnished with probe metering ports.

