

MA-240K QUINTUPLEX PUMP (MEASUREMENTS SHOWN IN INCHES)

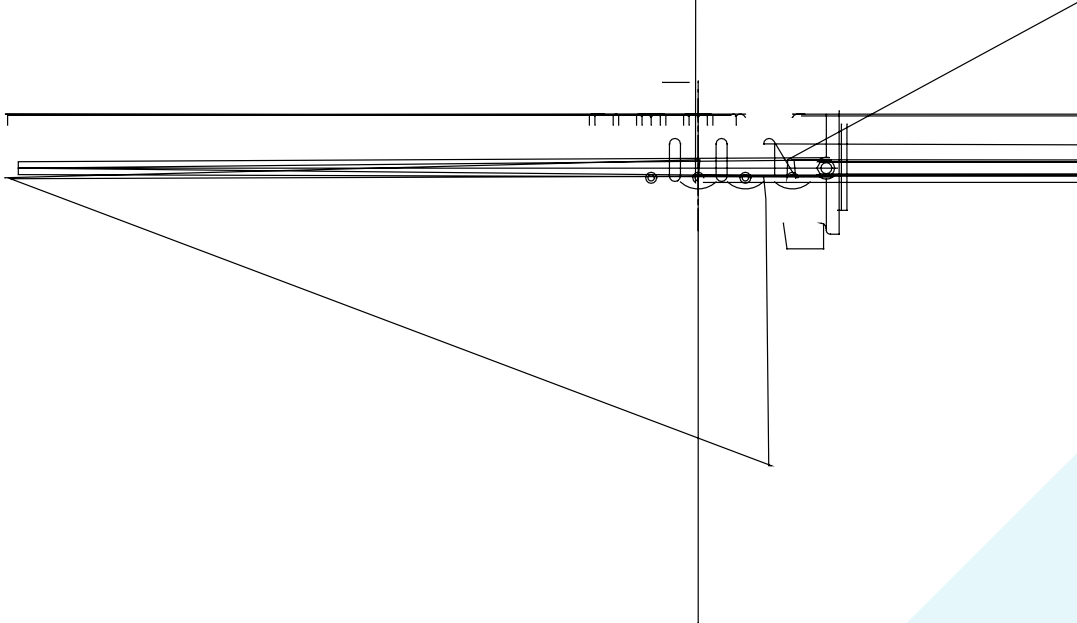

MA-240M QUINTUPLEX PUMP (MEASUREMENTS SHOWN IN INCHES)

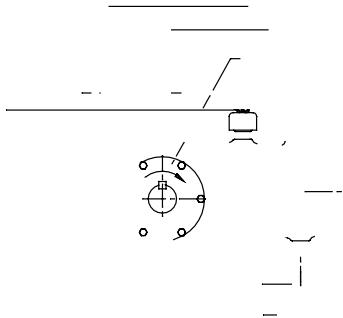
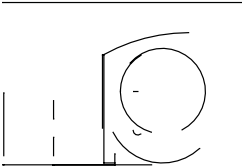

MA-240L QUINTUPLEX PUMP (MEASUREMENTS SHOWN IN INCHES)

ENGINEERING DATA - MA-240K, MA-240M, MA-240L AND MA-240H QUINTUPLEX PLUNGER PUMP

POWER END ENGINEERING DATA

Oil Capacity
Power End Oiling System

Pressure Lubrication System

Crosshead, Full Cylindrical

Plunger Type Rokide

Other Types of plungers are also available such as ceramic & Tungsten Carbide)
Stuf ng Boxes, Field-Removable and Replaceable:

MA-240K QUINTUPLEX PUMP (MEASUREMENTS SHOWN IN INCHES)



MA-240M QUINTUPLEX PUMP (MEASUREMENTS SHOWN IN INCHES)

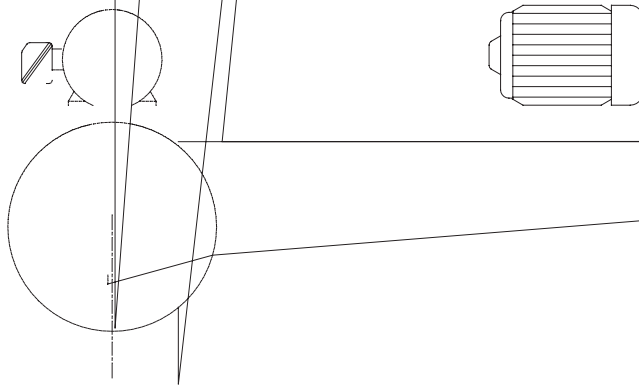

MA-240L QUINTUPLEX PUMP (MEASUREMENTS SHOWN IN INCHES)

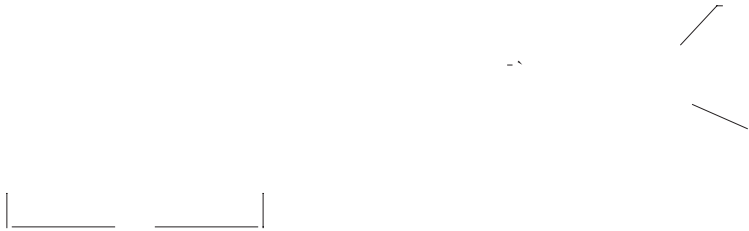



All indicated Pentair trademarks and logos are property of Pentair. Third party registered and unregistered trademarks and logos are the property of their respective owners. Because we are continuously improving our products and services, Pentair reserves the right to change specifications without prior notice. Pentair is an equal opportunity employer.

MA 1029 (12-15-2020) ©2020 Pentair. All Rights Reserved.