

High Pressure Reciprocating Pump

Understanding Your Needs

The Myers BXM series combines manufacturing expertise and understanding of applications to provide a pump with strength and versatility for any demanding high-pressure job.

Contact your Pentair sales representative or customer service at 419-289-1144 for more details.

Wide Performance Range

JSP OSP
8W RSVLEDU

Rugged design for continuous operation

6 ROLHFS DLVRE B Q
(DW OF DLVRE X SXUE U RUF DWLRQ
6 WHHO

V X F D W L Q Y I D D Q G H W R B S K Y U S R P V W H P

Whisper Quiet Operation

2 Y H V U S K L M B F O D E V Y I D D Q G H R Z I L O R G L O W Q G H U

Dimensional Data

[Dimensions in mm]

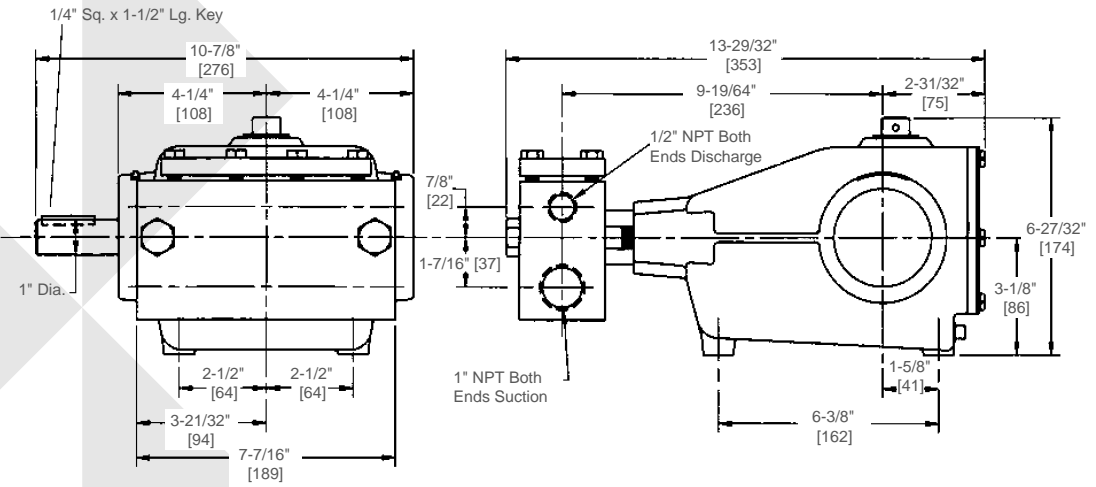

Product Capabilities, Specifications

Catalog Number	Max. Rated Capacity	Max. Rated Pressure	Temp. Rating F (C)	Approx. Weight lbs. (kg)	Sizes in inches (mm)						
					Cylinder Bore	Piston	Suction Size NPT	Discharge Size NPT	Input Shaft	Keyway	
BXM6-15	8 gpm 30.3 lpm	1500 psi 103.4 bar	140 (60)	60 (27.2)	1 (25.4)	1-1/16 (26.99)	1 (25.4)	1/2 (12.7)	1 (25.4)	1/4 x 1/8 (6.35 x 3.18)	

Note: Consult factory for applications outside of these recommendations.

) O X Q G

1. % R S Seal monoblock optional aluminum-bronze.
2. 3 L V S W R P F E Reinforced nitrile V-ring with aluminum-bronze
3. % R S Solid one-piece, cast iron crankcase. Acrylic window for oil l
4. & U D Q N W Motive-type ductile iron. Standard is right-hand drive. Left-hand drive available.
5. 0 D % G D B L C a M s for crankshaft.
6. Continuous Splash Lubrication.
7. & R Q Q L H M L Q length zinc alloy for durability.
8. & U R V M i g h t s D e G w h zinc alloy.
9. & \ O L C G H U i a-ceramic.
10. 9 D S V H F i e e p l e y stainless steel for less maintenance.
11. , Q O H W T both sides.
12. ' L V F K D U P H both sides.

Horsepower Requirements

		BXM							
GPM [LPM]	RPM								



740 EAST 9TH STREET,
ASHLAND, OHIO 44805
WWW.FEMYERS.COM

490 PINEBUSH ROAD, UNIT 4,
CAMBRIDGE, ONTARIO N1T 0A5
WWW.FEMYERS.COM

Because we are continuously improving our products and services, Pentair reserves the right to change specifications without prior notice.
K3235 01/06/14 © 2014 Pentair. All Rights Reserved.