

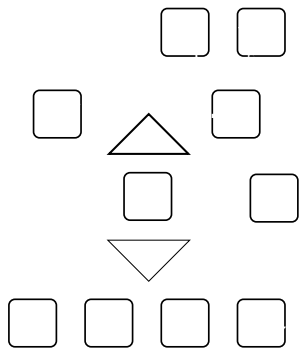


Hazardous voltage.

Warning: High voltage. Do not touch the terminals.



Warning: High voltage. Do not touch the terminals.

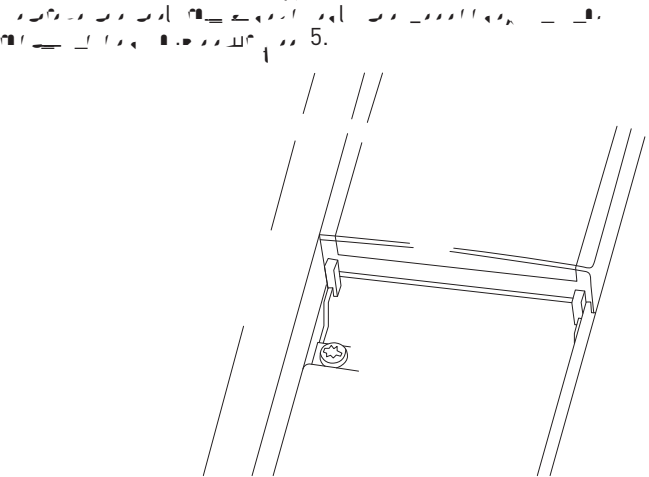


Step 2: Remove the MCB 109 Option Card

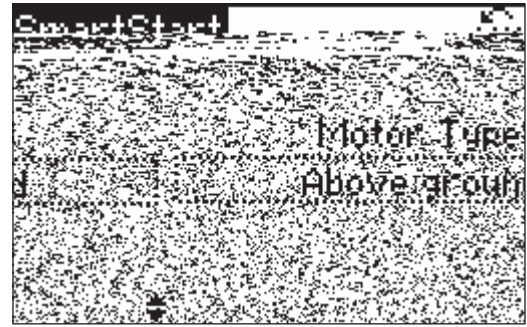
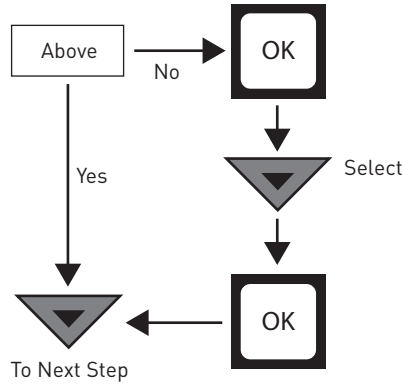


Figure 4.

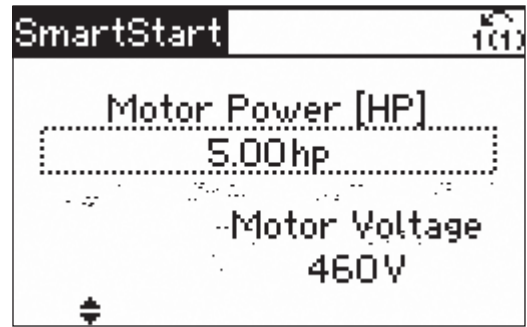
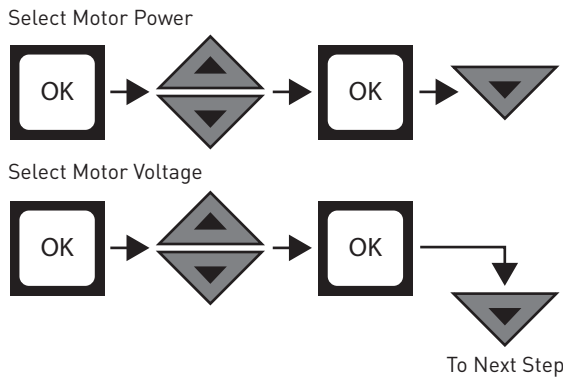
Step 3: Install terminal block.



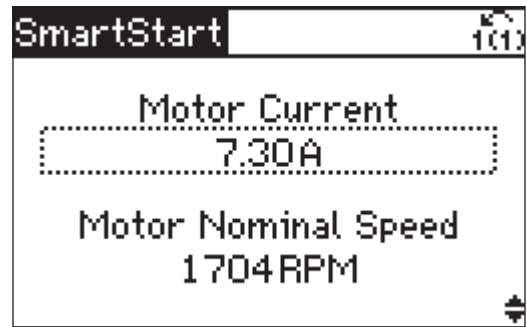
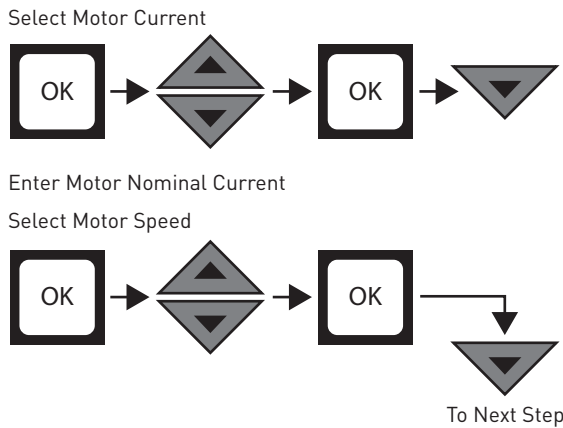
5



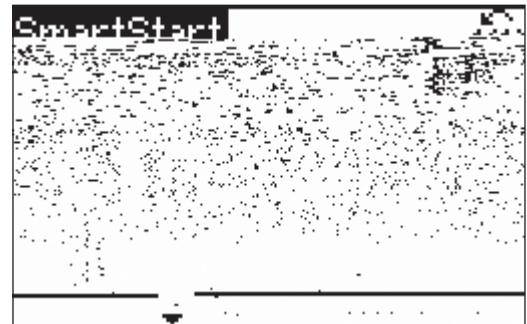
6



7



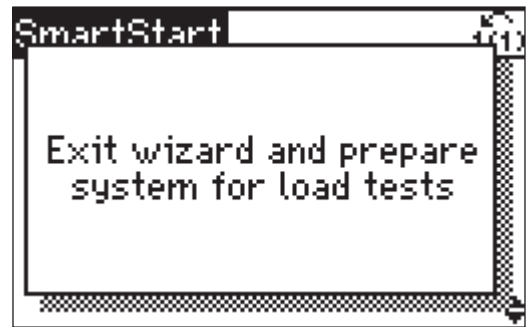
8



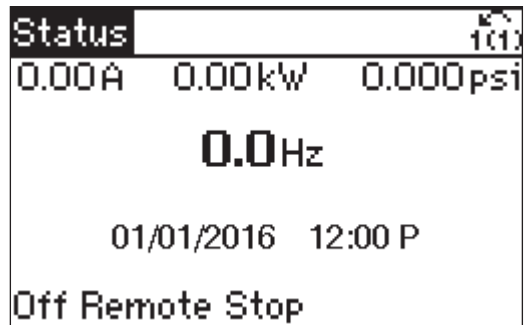
9



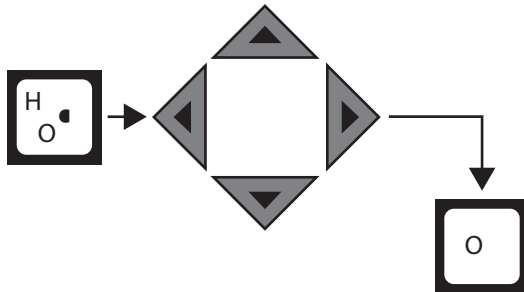
To Next Step



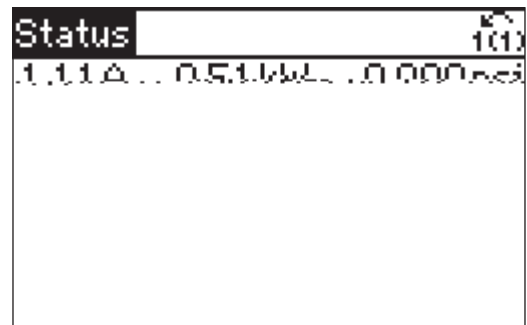
Handwritten notes for step 9, including a large '9' and some illegible text.



10



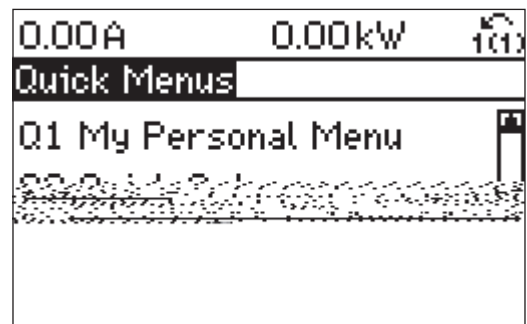
Handwritten notes for step 10, including a large '10' and some illegible text.



11



To SmartStart



Adjust Live Zero Settings

20



Status		f(1)
12.4A	5.76kW	0.000psi
6.6Hz		
01/01/2016 12:00 P		
Auto Remote Ramping		

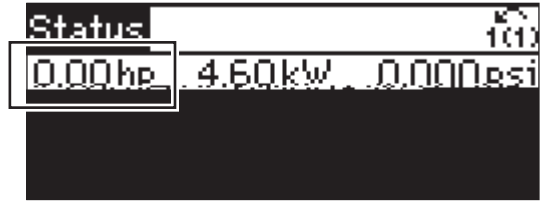
21

1. The Live Zero button is located on the right side of the screen. Pressing this button will allow you to adjust the live zero settings for the current channel. The Live Zero button is located on the right side of the screen. Pressing this button will allow you to adjust the live zero settings for the current channel.



A6

Press the **Q** button on the remote control.



22-35

A7

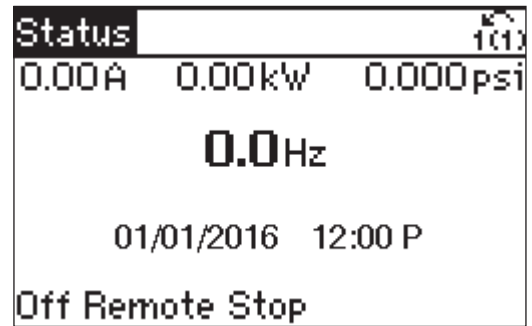
Press the **Q** button on the remote control.

22-37

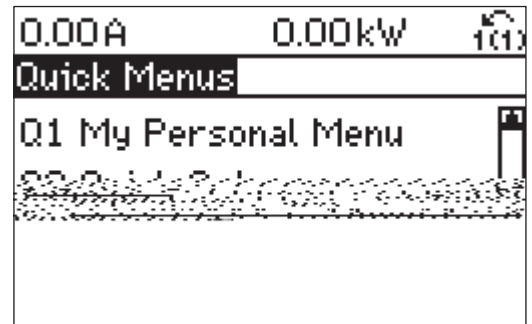
22-3

A8

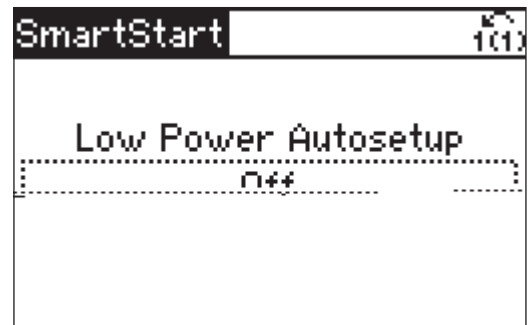
Press the **Q** button on the remote control.




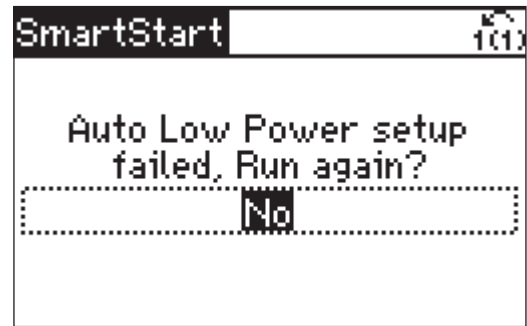
A9



A10




A11 

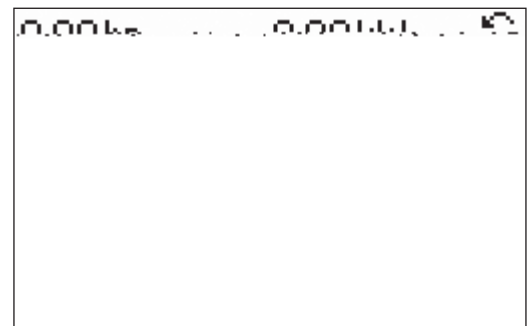


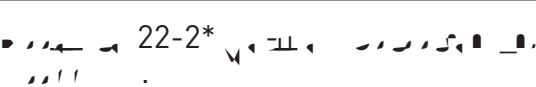
A12

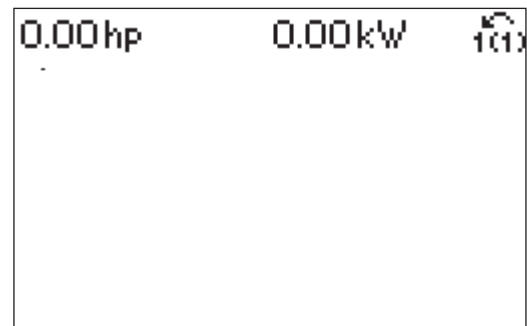


Adjust Sleep Parameters

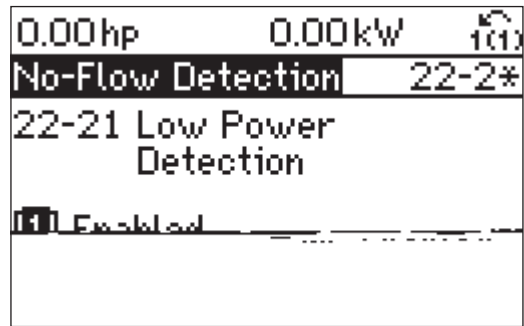
A13 



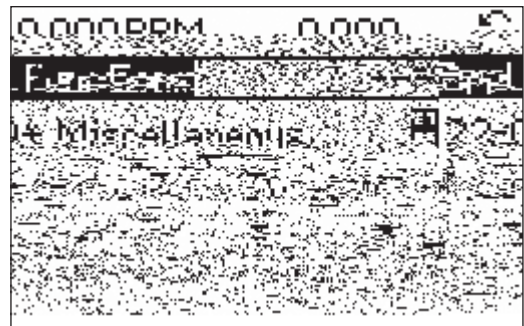
A14 



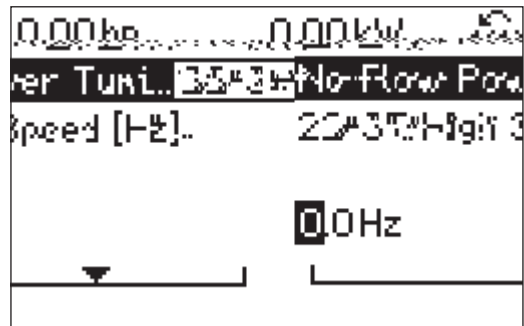
A15 22-21



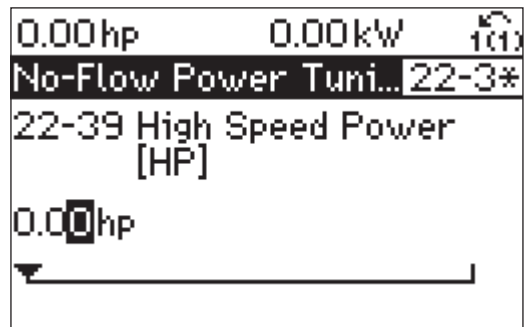
A16 22-3*



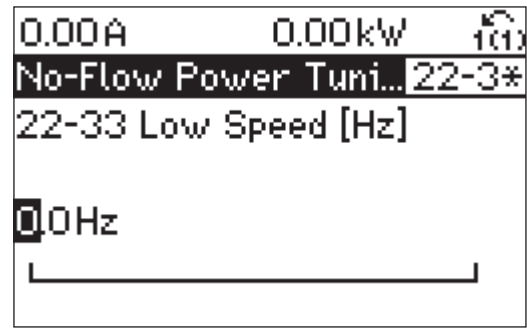
A17 22-37



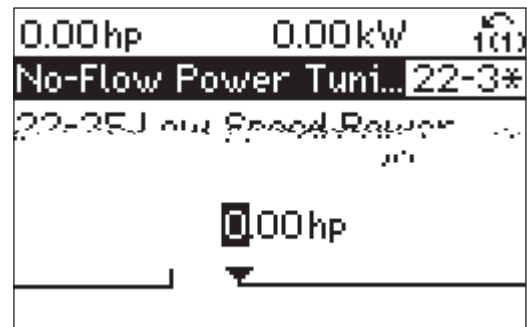
A18 22-3



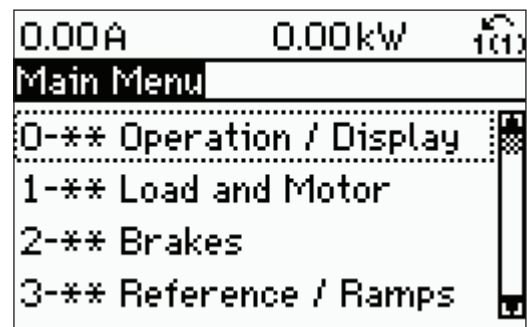
A19 22-33 30



A20 22-35 6

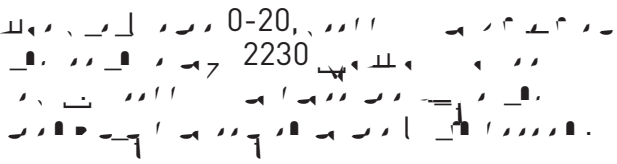
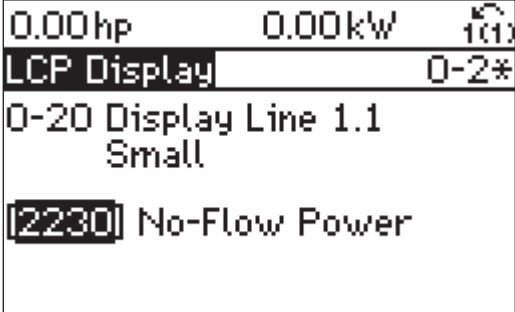


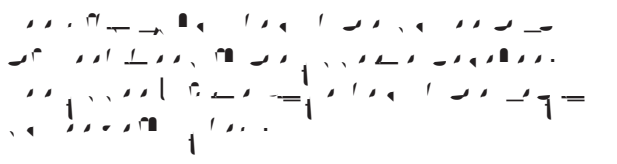
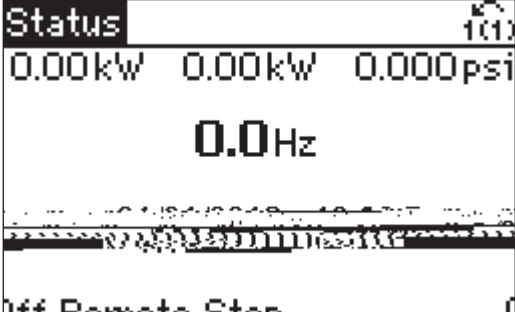
A21 0-**





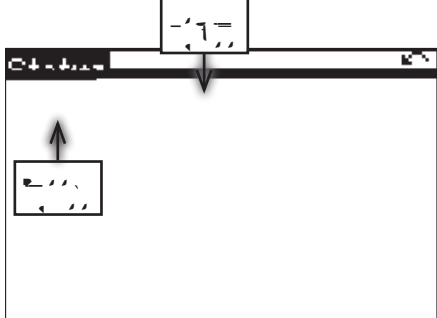
A22 0-2*

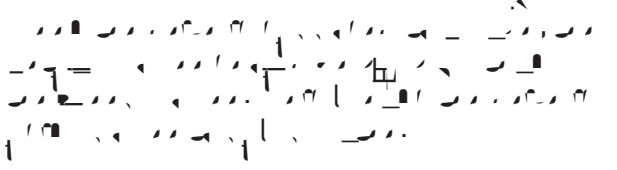
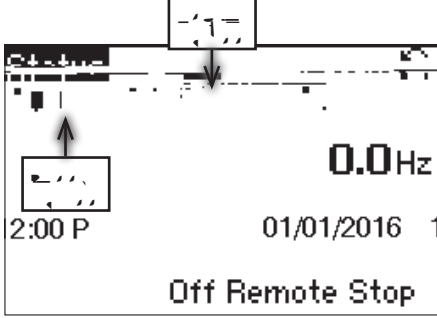


A23  

A24  

A25 

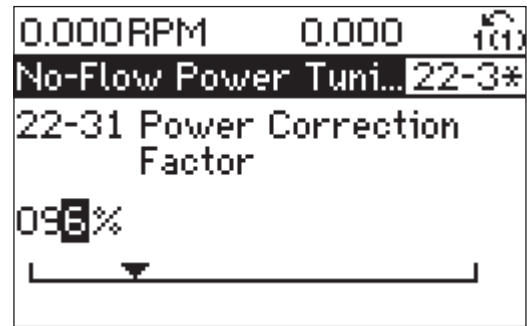
A26 Sleep (No Flow)  

Awake (with Low Flow)  

A27 

A28 SLEEPS USING WATER

22-31
100% → 6%.



A29

22-31

A30 WON'T SLEEP WHEN NOT USING WATER

22-31
100% → 104%.

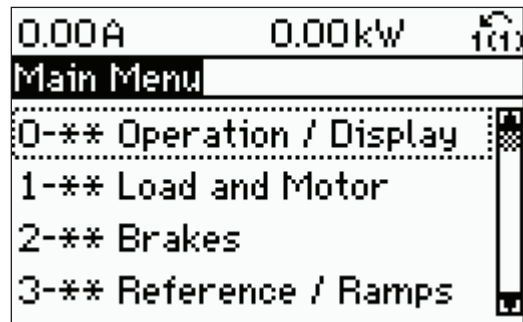


A31

22-31

A32

0-**

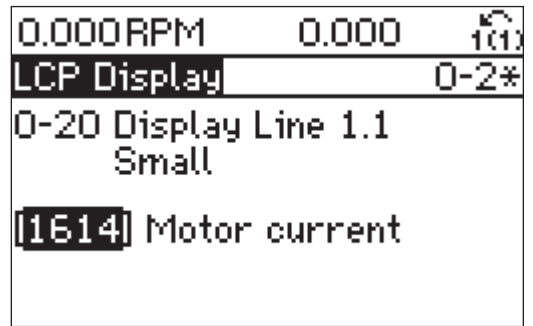


A33

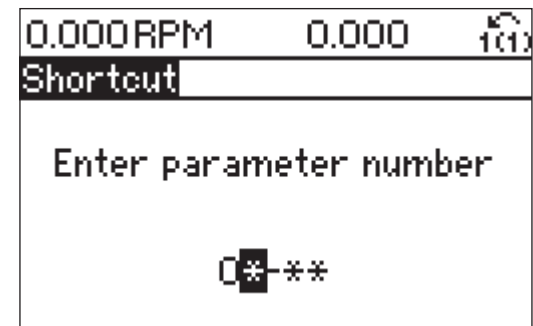
0-2*



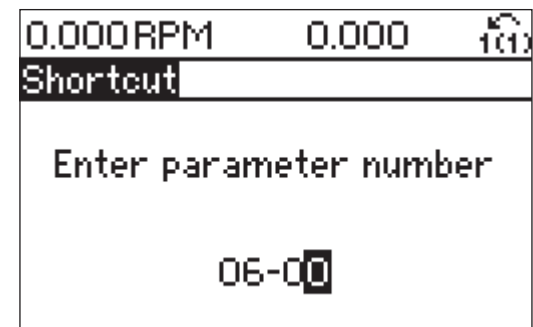
A34 0-20, 1614



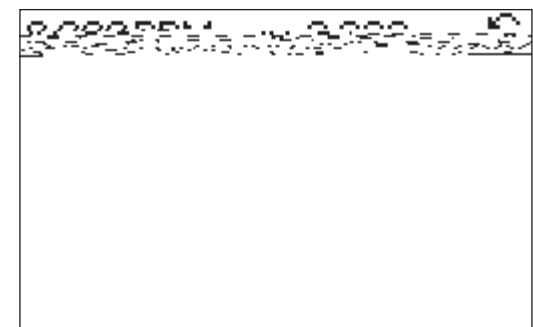
A35 (3)




A36 06-00



A37 000 01, 6-01




A38 



A39



Status		
12.4A	5.76kW	0.000psi
6.6Hz		
01/01/2016 12:00 P		
Auto Remote Ramping		

