

MARINE PRODUCT DATA SHEET

OEM

AF E MA < E .

|

|

▲

P

|

||

▲

P

APPL CA ON

12V DC Bait/Livewell tanks water circulation

P MP

Type: Centrifugal Pump, Magnetic Drive
Outlet Port: 3/4" Barb
Inlet Port: 3/4" NPT-M
Wash-Down Port: 1/2" NPT-F
Liquid: 130 °F [54 °C] Max
Prime: Flooded Inlet
Inlet PSI: 30 PSI [2.1 Bar] Max
Run Dry: Yes

ELEC CAL

Motor: 12VDC Permanent Magnet,
Continuous Duty
Protection: Need External Fuse (Not supplied)
Leads: 6/ft [1.8M] Tinned, Twisted Jacketed Cable
Fuse: 5 Amp Recommended
Control: No Control

MA E AL

Housing: High Strength Nylon
Impeller: Acetal
Hardware: Stainless Steel

APP O AL

Ignition Protected 8846, CE

PP N

Approx. Net Weight: 2.5 Lbs. [1.1 Kg] each
Approx. Lbs./Ctn. 14 Lbs. [6.3 Kg]
Pumps in Carton: 6
Approx. Carton Size: 16"L x 11"W x 11" H
[41cm x 28 cm x 28 cm]

ELA ED DOC MEN

Catalog: MS-030-140
Applications Spec Guide: MS-020-005
Installation Manual: 911-466
Aftermarket Warranty: 911-1045

The Bait Sentry Livewell Pumps are designed for easy installation and trouble-free operation. Magnetic Drive technology eliminates unnecessary failures. Motors keep running after ingesting debris or even when running dry. Patented anti-airlock feature allows the pump to clear trapped air in rough water or when boat is anchored. Includes dual port for easy washdown pump connection.

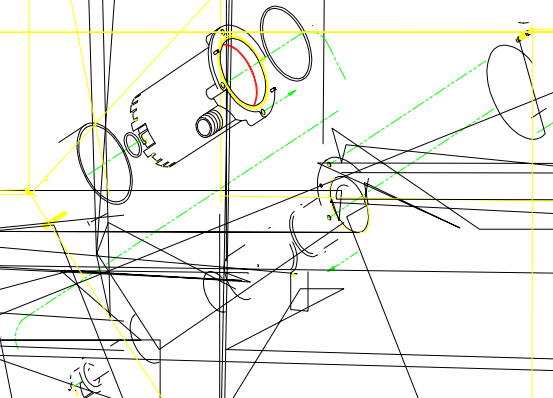

P E E

YP CAL PE FO MANCE