

STA-RITE® D Series

Self-Priming Centrifugal Pumps

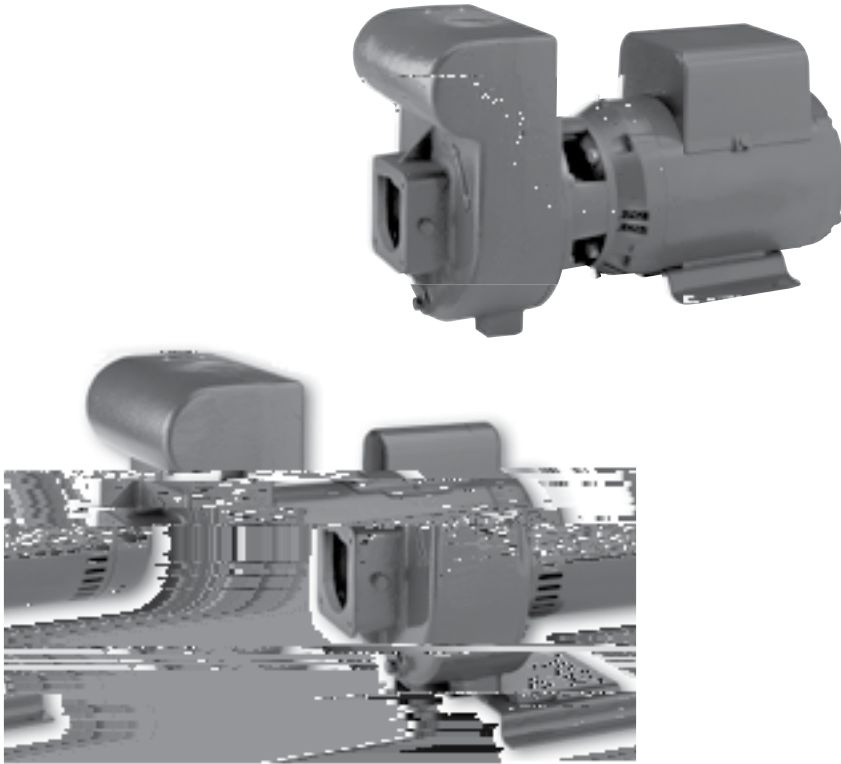

Some of the fastest priming pumps on the market. Available in high head or medium head series. Features mechanical seals, easy service design, heavy-duty motors, rugged construction. Available in 1 through 5 HP.

Optional 6" and 8" Trap Packages are available.

APPLICATIONS

STA-RITE® D Series

Self-Priming Centrifugal Pumps

6" AND 8" TRAP PACKAGES

Catalog Number		Description	Suction Port Size	Approx. Wt. Lbs.
51	6"		2"	20
76			3"	4
98	8"		3"	40

STA-RITE® D Series

Self-Priming Centrifugal Pumps

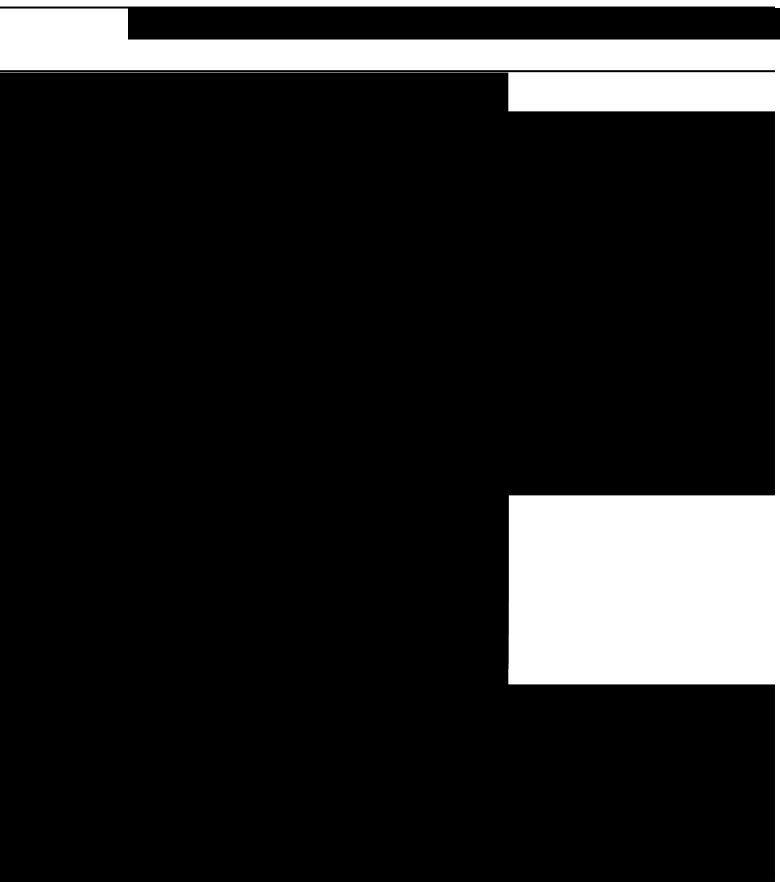

STA-RITE® D Series

Self-Priming Centrifugal Pumps



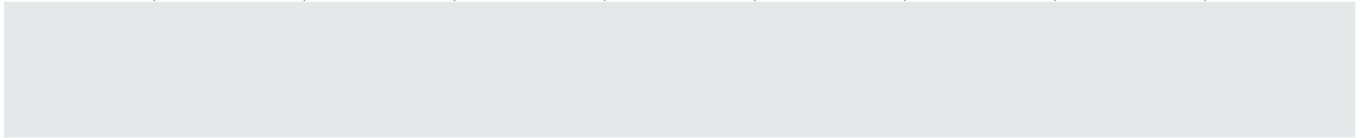

STA-RITE® D Series

Self-priming centrifugal pumps

OUTLINE DIMENSIONS

